



# GP® TITANTANK®

## Installation Guidance

GP® TITANTANK® - a waterproofing gas and hydrocarbon resistant - Self Adhesive Membrane, is a bituminous gas, voc/hydrocarbon proof and water proof sheet, composed of self-adhesive SBS polymer modified bitumen with an upper surface finish of GP® TITANFLEX® membrane and a lower surface finish or siliconized polypropylene release film. GP® TITANTANK® is used for the Gas/VOC/Hydrocarbon/waterproofing of underground structures where harmful ground gasses and contaminants are anticipated, or as a self-adhesive accessory to the GP® TITANTECH® membrane system.

Self Adhesive Membranes are bituminous membranes, composed of self-adhesive SBS polymer modified bitumen incorporating an upper membrane element, and a lower surface finish of siliconized release film. The type of SAM is dependent on the application scenario as prescribed below, and they are generally used for the gas/waterproofing of underground structures where harmful ground gasses are anticipated, and as a self-adhesive accessory to GP® membrane systems.

JUTA UK – radon, ground gas, vapour, air and moisture barrier characteristic properties:

- High Chemical Resistance
- High resistance to Ground Gasses
- Long Term Durability (Performance guaranteed for the lifetime of the building)
- Compatible with all building materials
- Manufactured to meet the most up to date British Standards and guidance.

<b>Width</b>	0.9 m
<b>Length</b>	20 m
<b>Coverage</b>	18 m <sup>2</sup> / roll
<b>Weight</b>	22 kg



## Additional Products & Accessories:

- **GP® Primer** is a low viscosity quick drying primer. The primer is modified to provide improved damp substrate tolerance and membrane bonding relative to non-modified bituminous primers. GP Primer can be applied directly onto green concrete, masonry, metal and wood. It should be applied without thinning and should be brush or roller applied to ensure an even coverage. Coverage rate 6-10m<sup>2</sup> / litre depending on porosity of substrate, and drying time 30–60mins depending on conditions. Supplied in 5 or 25 litre drums. Please refer to GP Primer TDS for further information on coverage rates.
- **GP® Protection Board** is a high density board which are supplied in 3.0mm x 1.2m x 2.4m sizes.
- **GP® Protection Fleece** is a 300g nonwoven geotextile and is supplied in 2m x 100m rolls.
- **PD1700** is a geo composite drainage and protection board to be used as protection on below ground applications. The dimpled profile of the membrane creates a void between the earth and membrane to avoid hydrostatic pressure onto the membrane and aid the path of drainage down external land drain locations.

## General Precautions:

- It is recommended that JUTA Self-Adhesive Membranes are installed in ambient air temperatures in excess of 10°C.
- Ingress of water into the installation area should be prohibited.
- In all cases, the surface onto which the Barrier is to be applied should be smooth, dry, clean and free from debris or detritus material which may cause damage to the Barrier.
- In all cases it is recommended the installation of barrier geomembranes is completed by a suitably qualified and accredited installers (NVQ level 2/TWI/CSWIP or equivalent). JUTA UK can offer advice as to suitable/ recommended installers.
- Appropriate PPE should be worn at all times during handling, placement and fixing of the Barrier.
- Vehicular traffic directly on top of the barrier should be avoided.
- Foot traffic directly on top of the barrier should be restricted.
- Where either Vehicular or Foot traffic is unavoidable, protective measures should be utilised to prevent damage to the Barrier. (Use of protection fleece and/or protection boards)
- Smoking, and naked flames are strictly prohibited.
- GP® Membranes should not be left exposed for prolonged periods and should be covered as soon as practically possible to prevent UV degradation..





## General Installation Notes:

- All construction should conform to the Building Regulations, Codes of Practice and British Standards in current use at the time the building is being constructed. It is recommended that reference is made to BS8102:2009, and BS8485:2015.
- All Surfaces should be smooth clean, dry (to a depth of 1-2mm), sound and free from frost, oil, grease, condensation and other contamination. Any voids or hollows must be made good to a flush finish with a suitable filler. Any sharp edges or high points should be eliminated. Powdery or flaking surfaces should be removed by suitable means. Internal corners should be eased with a min. 40 x 40mm cement fillet, to assist application, similarly, external corners should be chamfered or rounded where required.
- Concrete surfaces: Horizontal surfaces should preferably be smooth, however lightly tamped (3-4mm peak to trough profile), brushed or floated surfaces may also be acceptable.
- Masonry: Should be sound with joints flush pointed before the membrane is applied. Open textured surfaces should be sealed with a sand/cement slurry or render to provide a suitable surface. If existing surfaces are very rough, they may require rendering.



## Application Method:

- Application of Self-Adhesive Gas Membranes should not be attempted in temperatures below 10°C.
- Apply one coat of GP® Primer to all vertical or inclined surfaces. The primer should be applied where required by brush, roller or spray at a coverage of approximately 7m<sup>2</sup>/litre (Refer to TDS for coverage info). GP® Primer should dry in 30–60mins depending on site conditions. GP® Primer should be covered as soon as it is dry and should not be left exposed for longer than seven days. Do not use GP® Primer on insulation boards or insulated concrete formwork (ICF) systems. Contact JUTA for further information if required.
- Vertical applications should be supported immediately after application, or temporary support provided. Maximum unsupported height of membrane should not exceed 600mm.
- JUTA Self-Adhesive Gas Membranes should be applied from the top down similar to wallpaper. Remove the separating paper progressively from one end of the roll, and press the adhesive coated surface firmly onto the prepared substrate. Smooth out the membrane working from the centre to the edges to remove air pockets. Any remaining bubbles should be slit with a sharp knife and re-adhered. Patches of sufficient size must then be applied over the slits or any other damaged areas to maintain a minimum overlap of 100mm. A hard roller (silicone) should then be used to firm down the whole area.
- Subsequent rolls should then be lapped onto the previous roll. Edge laps should be a minimum of 50mm, onto the backing film, and end laps 100mm. The overlaps should not be primed, but should be rolled with a hard roller, to ensure good adhesion.
- JUTA Self-Adhesive Gas Membranes are not designed to be left exposed and should be protected from U.V. light within 28 days of application.
- Internal angles and corners should be eased with a min. 40mm cement fillet and be reinforced with a 300mm strip of SAM applied into the angle. The full membrane should then be dressed into the angle to form a triple layer. External corners should be covered with a 300mm wide strip of GP® SAM. GP® SAM is available in 300mm wide rolls to assist in carrying out angles and projections.





## Application Method

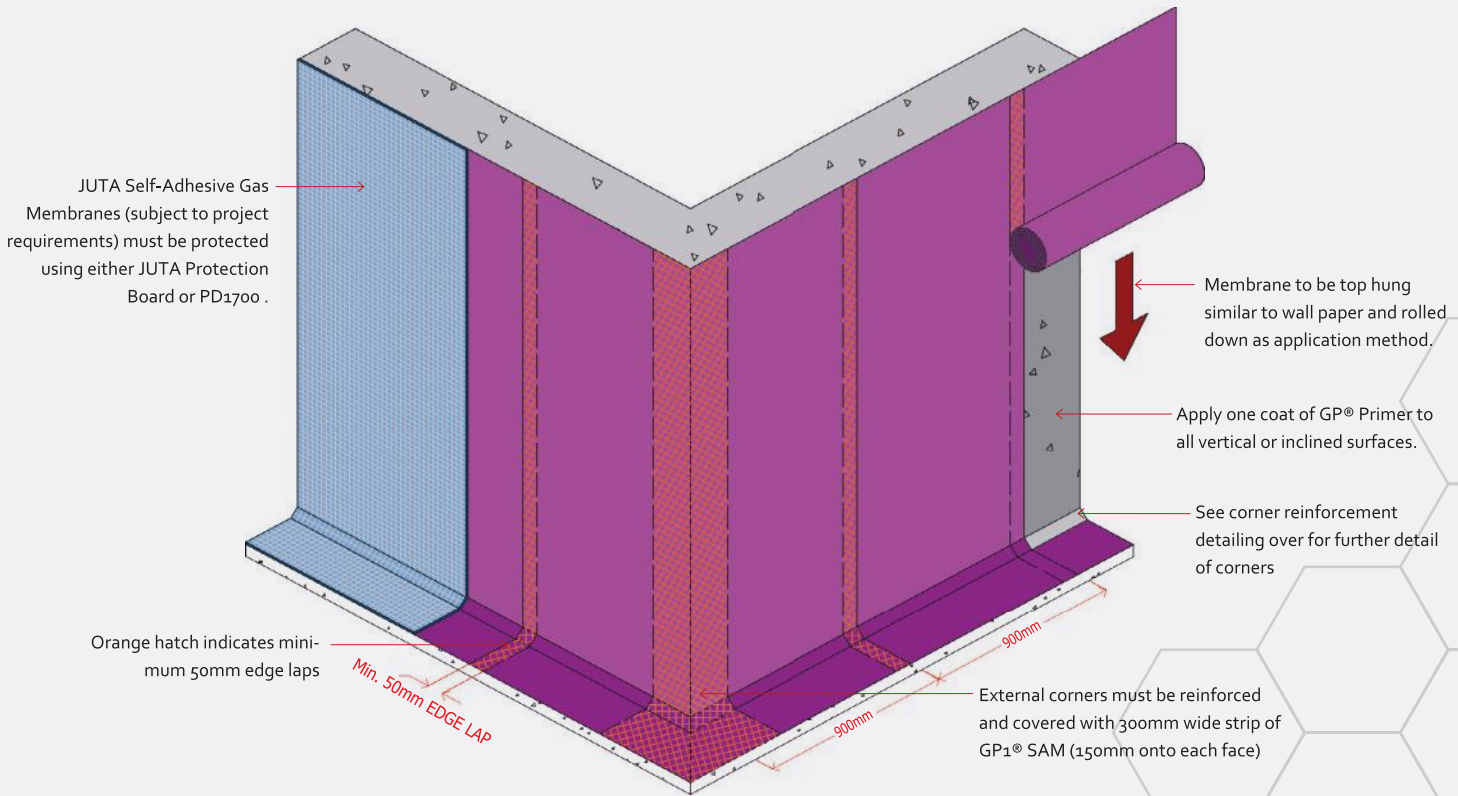



## Corner Detailing:

All 90 degree corners should be suitably reinforced to ensure robust corner detailing:

- Any internal corners should be eased with a minimum 40mm sand/ cement fillet to assist application.
- A 300mm band of JUTA Self-Adhesive Gas Membrane (subject to project requirements) is applied into the corners lapping 150mm onto the wall and 150mm onto the toe/ screed below slab as project specific detail. Ensure that the wall is primed prior to installation of corner reinforcements.
- JUTA Self-Adhesive Gas Membrane (subject to project requirements) is applied to the wall and overlaps the corner reinforcement. The membrane should be protected with JUTA PD 1700 as soon as practically possible and backfilled.

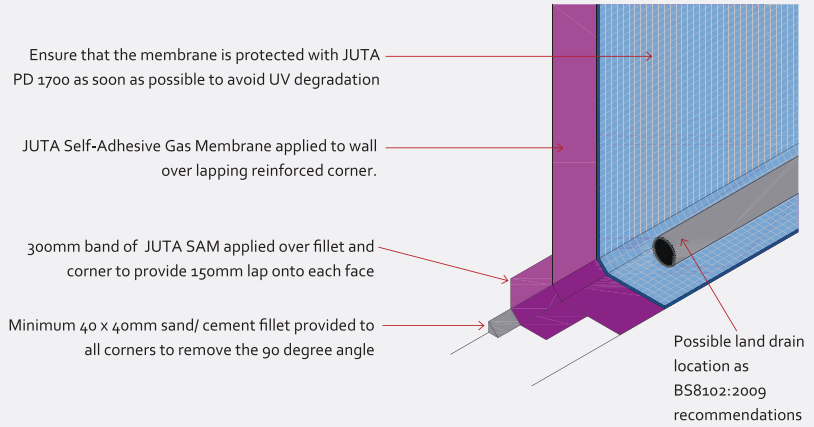

Ensure that the membrane is protected with JUTA PD 1700 as soon as possible to avoid UV degradation

JUTA Self-Adhesive Gas Membrane applied to wall over lapping reinforced corner.

300mm band of JUTA SAM applied over fillet and corner to provide 150mm lap onto each face

Minimum 40 x 40mm sand/ cement fillet provided to all corners to remove the 90 degree angle

Possible land drain location as BS8102:2009 recommendations

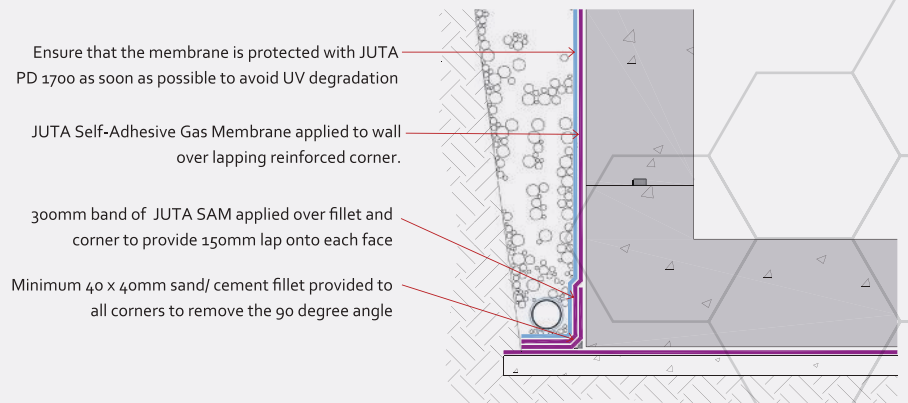

Ensure that the membrane is protected with JUTA PD 1700 as soon as possible to avoid UV degradation

JUTA Self-Adhesive Gas Membrane applied to wall over lapping reinforced corner.

300mm band of JUTA SAM applied over fillet and corner to provide 150mm lap onto each face

Minimum 40 x 40mm sand/ cement fillet provided to all corners to remove the 90 degree angle



## Stanchion Detailing:

Sealing around stanchion using JUTA Self-Adhesive Gas Membranes can be achieved with the following method:

- Cut square or rectangle in the propriety GP® Membrane to suit the steel baseplate dimensions. Ensure that membrane is laid as tightly as possible around the baseplate.
- With the membrane in place, self-adhesive JUTA Self-Adhesive Membranes is cut and applied to the steel around the flanges to create a good seal extending a minimum 150mm up the vertical face of the steel. The GP1 SAM should then overlap and seal to the GP1® Membrane providing a minimum 100mm lap.



**JUTA SELF-ADHESIVE  
GAS MEMBRANE**  
APPLIED ONTO EDGE OF GP1 AND  
LAPPED ONTO STEEL & BASE PLATE.  
NB - GALVANIZED STEEL DOES NOT  
REQUIRE PRIMER

**JUTA GAS MEMBRANE**  
GP1/GP4/ GP DPC - SUBJECT TO  
PROJECT REQUIREMENTS

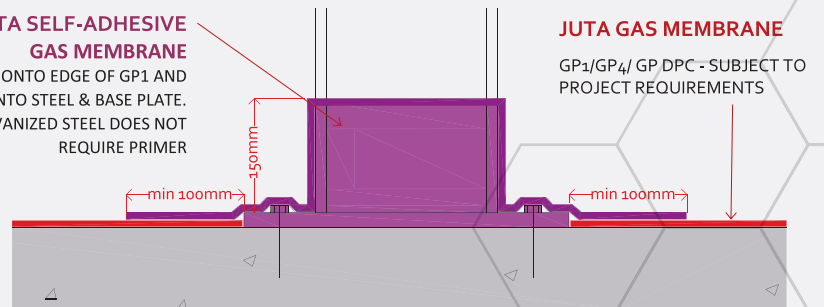

**JUTA SELF-ADHESIVE  
GAS MEMBRANE**  
APPLIED ONTO EDGE OF GP1 AND  
LAPPED ONTO STEEL & BASE PLATE.  
NB - GALVANIZED STEEL DOES NOT  
REQUIRE PRIMER

**JUTA GAS MEMBRANE**  
GP1/GP4/ GP DPC - SUBJECT TO  
PROJECT REQUIREMENTS